

# **BIESSE ROVER A**

NC processing centre



When  
competitiveness  
means meeting  
all requirements

Prove

Made **in** Biesse

## The market demands

a change in manufacturing processes which enables companies to **accept the largest possible number of orders**. This is coupled with the need to maintain high quality standards whilst offering product customisation with **quick and defined delivery times**, as well as responding to the needs of highly creative designers.

## Biesse meets these requirements

with **technological solutions** that influence and support technical expertise as well as process and material knowledge. **Rover A** is the NC processing centre for the manufacturing of furniture and window/door frames. Thanks to its comprehensive range of sizes and configurations, it is ideally suited to small and large joineries that need to manufacture either odd-sized products or standard products in small batches.

- ✓ **Machine customisation depending on different production requirements.**
- ✓ **High finish quality.**
- ✓ **Reduced tool changeover time.**
- ✓ **Ability to process large sizes.**
- ✓ **High-tech becomes accessible and intuitive.**



A single processing  
centre for all types  
of machining  
operations



**ROVER A**  
NC processing centre



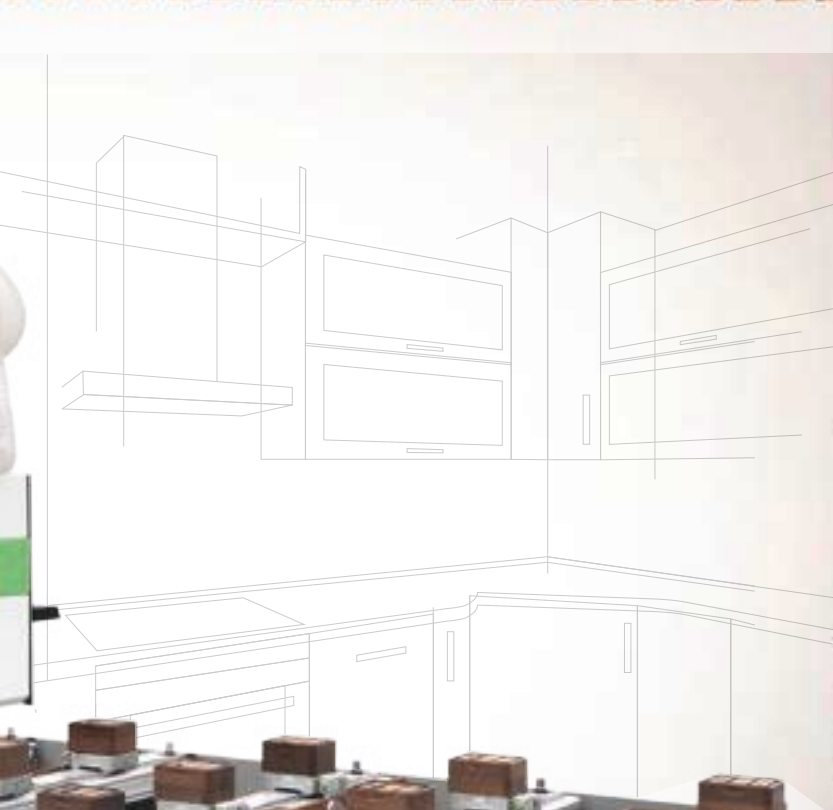

# Machine customisation depending on different production requirements

**A team of specialised sales engineers can understand production requirements and suggest the optimal machine configuration.**

4-axis configuration.



**A full configuration of the operating section** supports different machining operations whilst ensuring high product quality.





# 5-axis configuration.



The **5-axis**, high-tech operating section supports the processing of complex-shaped pieces, ensuring quality and precision.



# User-friendly technology

The 5-axis operating section, equipped with 13 kW HSD spindle and with 360° continuous rotation on the vertical and horizontal axes, enables the machining of complex-shaped pieces ensuring quality, precision and absolute reliability over time.

The high technological content of the machining centres most widely sold in the world meets the requirements of wood industry professionals.

A perfect combination of Biesse innovation and Italian genius.





# High finish quality



**Biesse uses the same high-tech components for all machines in the Rover range.**



Electrospindles, boring heads and aggregates are designed and manufactured for Biesse by **HSD**, the global leader in the mechatronics sector.



New **C Torque axis**: more precise, quicker, more rigid.



The new **BH30 2L boring head** is equipped with automatic lubrication and metal dust extraction cover to guarantee a longer life-span, and with liquid cooling to ensure maximum precision.

# Optimal cleaning of machined piece and work area



**Motorised conveyor belt** for the removal of chips and waste.



NC-controlled **deflector** (chip conveyor).



**Adjustable suction hood** with 6 settings.



# Reduced tool changeover time

The Biesse work table is guaranteed to hold the work piece securely in place and ensures quick and easy tool changeover.

Over 1 500 processing centres with EPS sold.



**Hyperclamp clamps**  
for rigid and precise blocking.



**Uniclamp clamps**  
with pneumatic system.



## SA (Set Up Assistance)

The assisted set-up work table suggests to the operator how to position the panel, (indicating the position of work tables and blocking systems) and protects the work area from any collisions with the tool.



## EPS (Electronic Positioning System)

supports the automatic rapid re-configuration of the entire work area. Positions work tables and carriages by means of separate engines, i.e. without engaging the operating section. The positioning of an area's work tables and carriages is performed during machining, whilst the machine is working on the opposite area.



The machine can house up to 98 aggregates and tools.

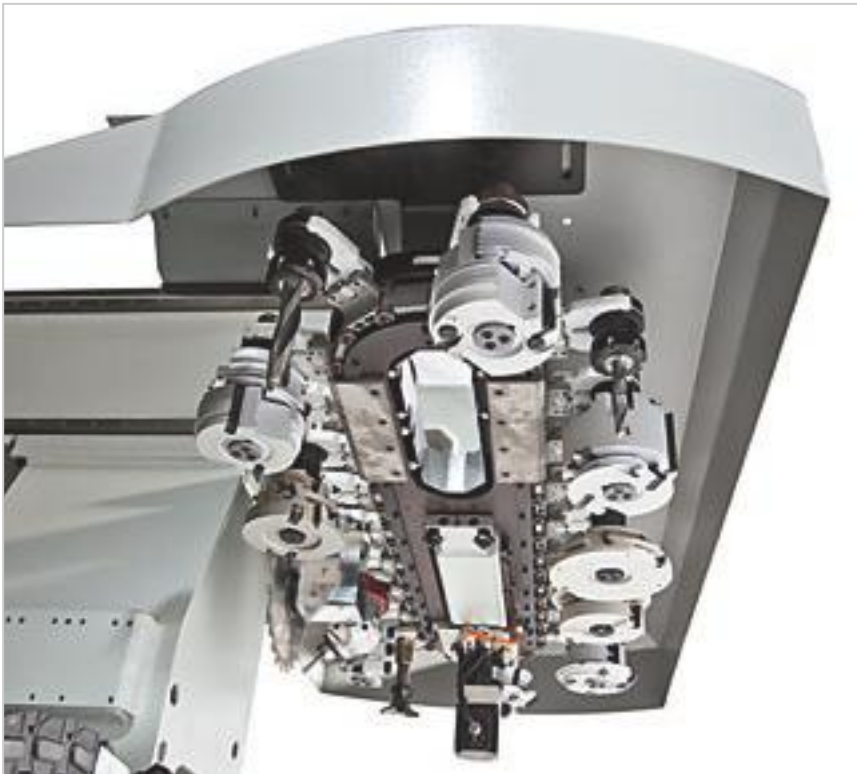

It is possible to switch from one machining operation to the next with no need for operator intervention for tool changes, thanks to the **large number of tools and aggregates** available at machine side.



The **Pick Up** station supports automatic tool-holder rack tooling.



Facilitated access during tool change operations thanks to **the openable front cowl**.



Quick and easy boring head change thanks to the exclusive **spindle snap-on coupling system**.

# Ability to process large sizes

The open front cowl supports the loading of very-large sizes (up to 2,100 mm in y direction) onto the machine, thus enabling the pre-sectioning phase to be skipped or machining operations to be performed for non-standard productions.

The cross-head thickness tracer enables operators to measure panel dimensions with absolute precision.



A comprehensive range of sizes to machine panels of all sizes, from which users can choose the most suitable one.

- Rover A 1425
- Rover A 1432
- Rover A 1443
- Rover A 1459
- Rover A 1625
- Rover A 1632
- Rover A 1643
- Rover A 1659

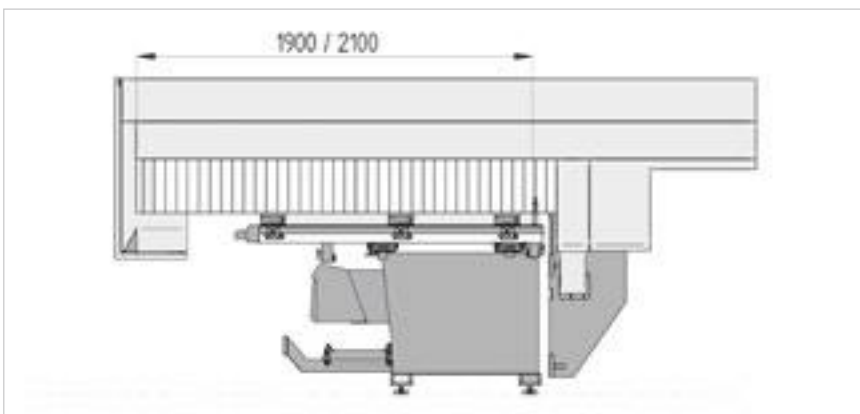

With Rover A, a manufacturer can accept orders for thicker panels thanks to the 225 mm work piece feed.





Two machines in one: the full functionality and quality of a true pantograph table are guaranteed by the **CFT (Convertible Flat Table)**, which supports the machining of thin panels, nesting and folding on bar work table.

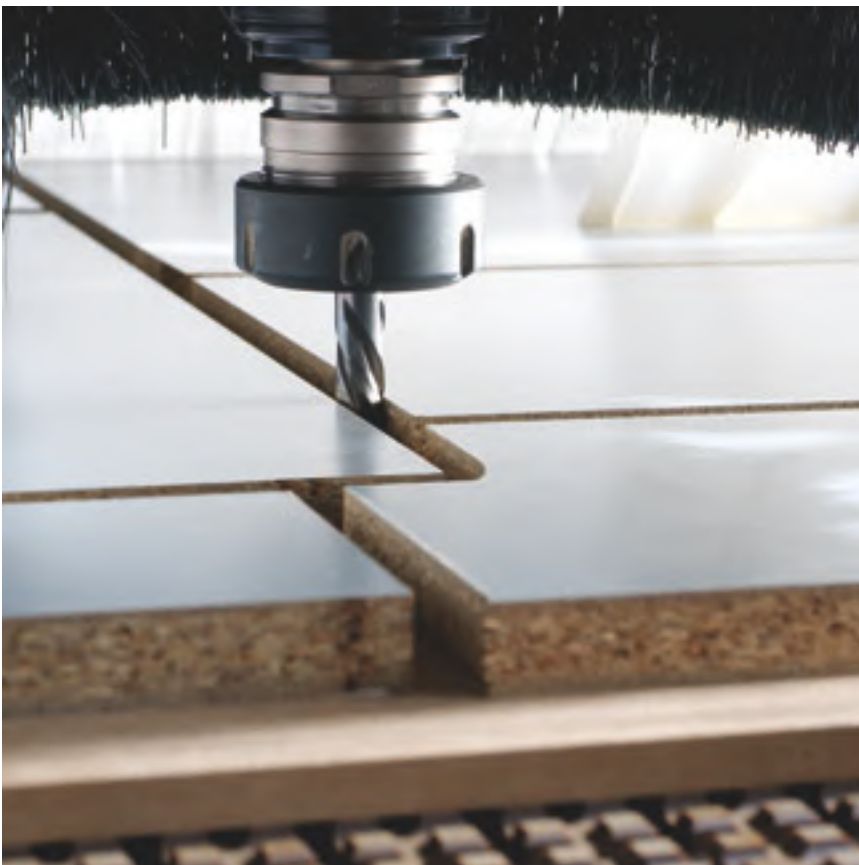

# Maximum operator safety



**Safety and flexibility thanks to the new bumpers combined with photocells with no footprint and dynamic tandem loading.**



**Pressure-sensitive floor mats** enable the machine to operate at constant maximum speed.

Perimeter guards with front access door.





22 overlaid layers of **side curtain guards** to protect the working unit, which are movable to enable the machine to work at maximum speed in total safety.



**Remote control panel** for direct and immediate operator control.

Maximum visibility of machining operation.  
**LED bar with 5 colours** showing machine status in real time.





# Practical design

The transparent polycarbonate reinforced protection door is designed to guarantee maximum visibility for the operator. Fitted with 5-colour LEDs indicating machine status, it ensures that processing phases can be easily and safely monitored.

An innovative yet simple design is the hallmark of Biesse's distinctive identity. The perfect combination of Italian genius and taste.

ROVER

# High-tech becomes accessible and intuitive



**bSolid** is a 3D cad cam software program that supports the performance of any machining operation thanks to vertical modules designed for specific manufacturing processes.

- ✓ Planning in just a few clicks, with endless possibilities.
- ✓ Simulating machining operations to visualise the piece prior to manufacturing and provide some guidance for the planning phase.
- ✓ Virtual prototyping of the piece to avoid collisions and ensure optimal machine equipment.

Watch the **bSolid** ad at: [youtube.com/biessegroup](https://youtube.com/biessegroup)





bSolid

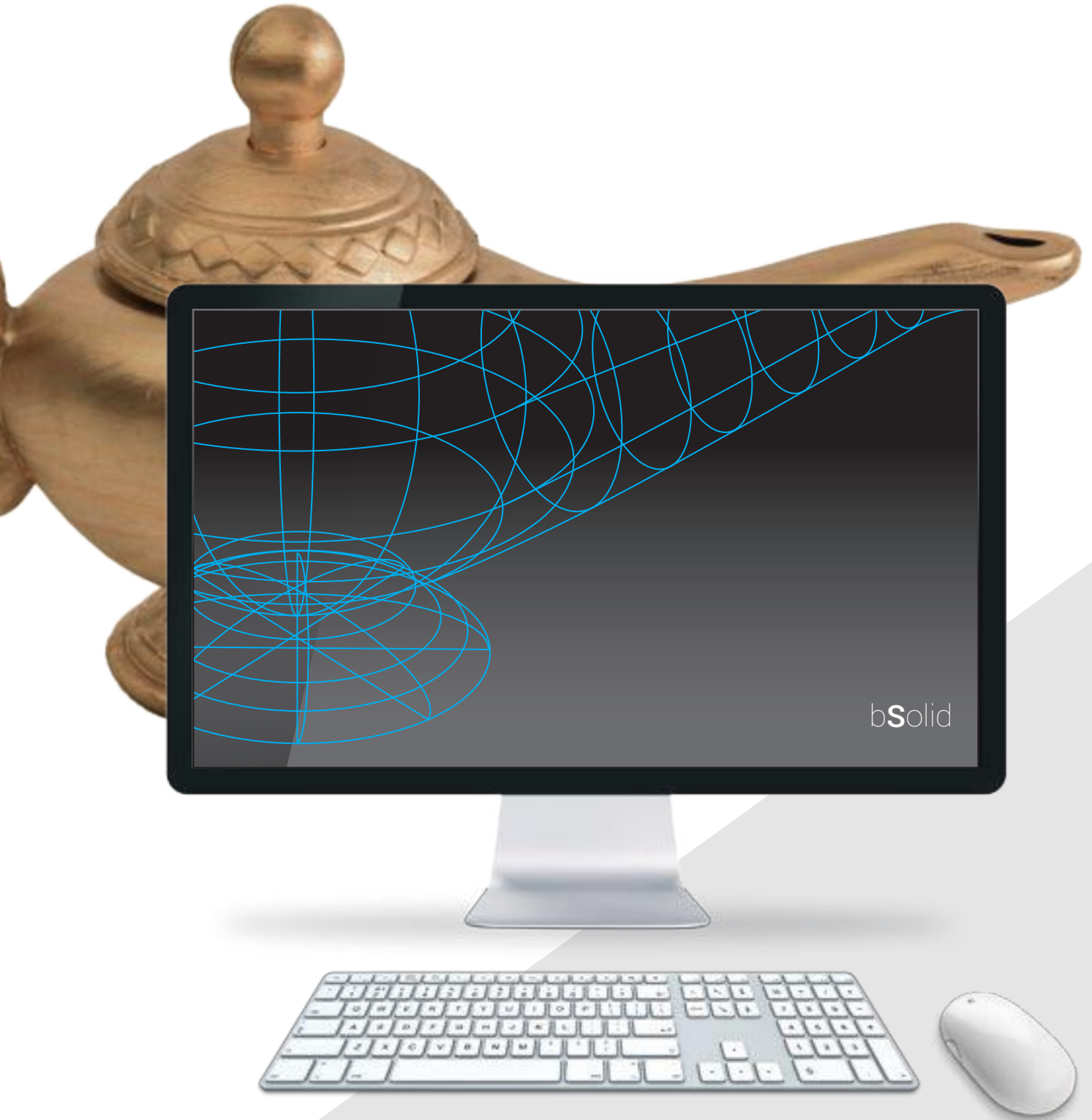

# Working unit configuration

4-axis configuration.

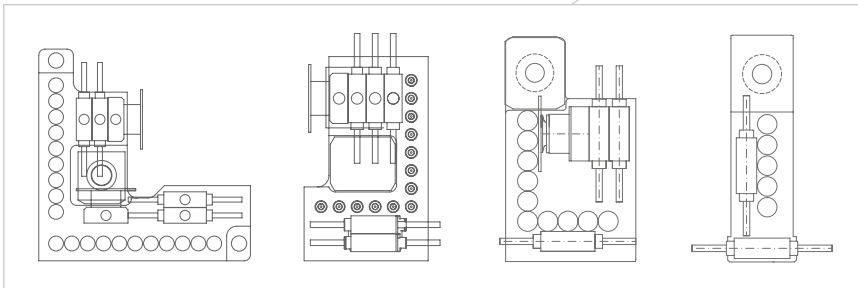

Available boring heads from 9 to 30 positions: BH30 2L - BH24 - BH17 - BH9. BH24 is not available for Rover A 14XX

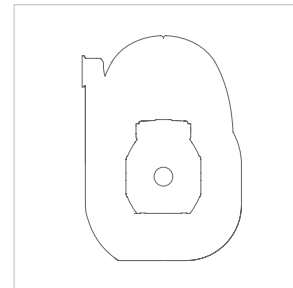

Milling unit with air or liquid cooling, ISO 30, HSK F63 and HSK E63 couplings and power from 13.2 kW to 19.2 kW.

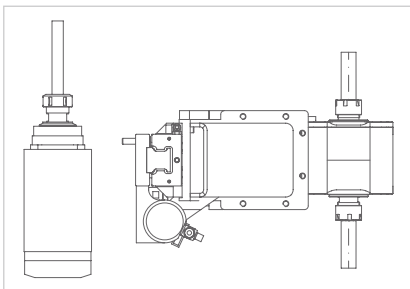

Horizontal 1 or 2 outlet milling units.

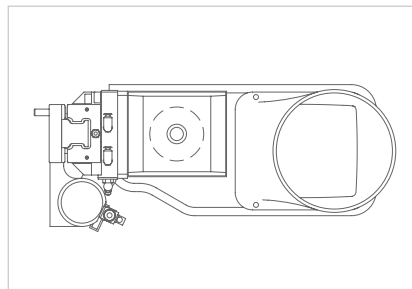

6 kW vertical milling unit.

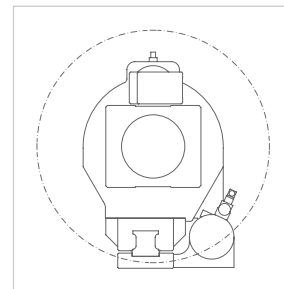

Multi-function, with 360° rotation.



# 5-axis configuration available for Rover A 16XX.

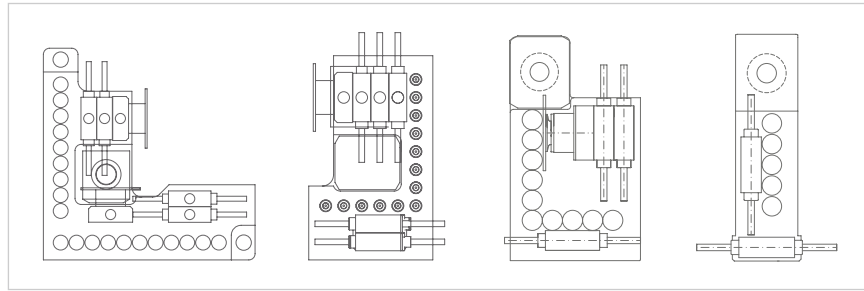
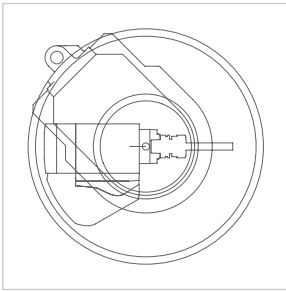

5 axis 13 kW – HSK F63.

Available boring heads from 9 to 30 positions:  
BH30 2L - BH24 - BH17 - BH9.

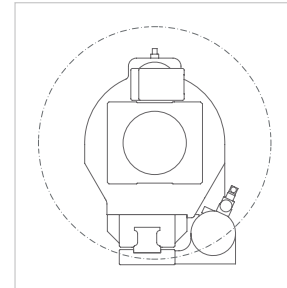
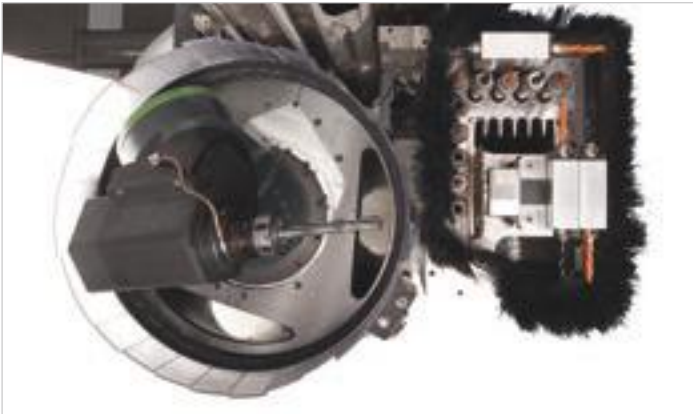

Multi-function,  
with 360° rotation.

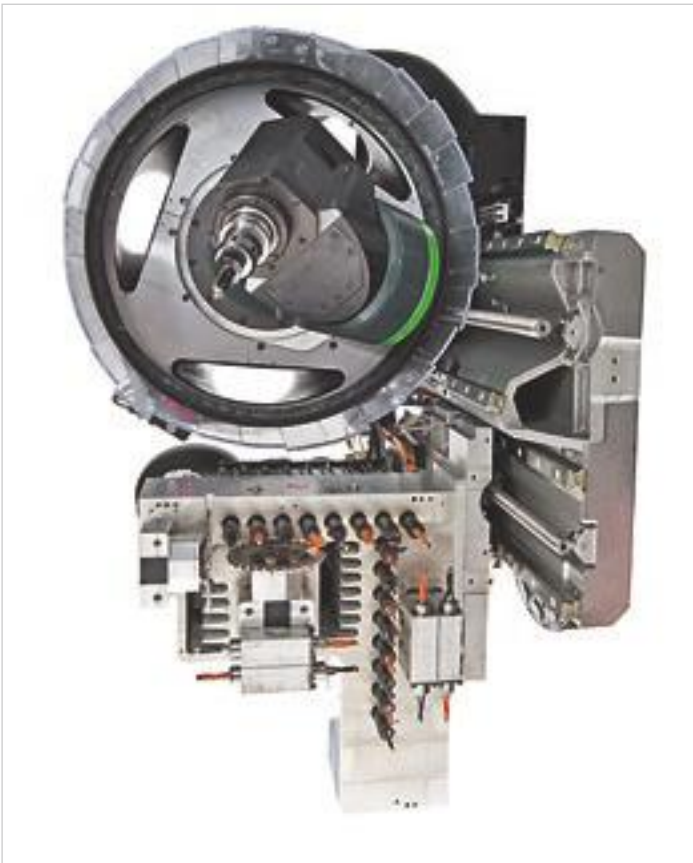



# Aggregates to perform any machining operation



## Improved finish, increased productivity



**The multi-function unit**, which can be continuously positioned over 360° by NC, can house aggregates used to carry out specific machining operations (pocketing for locks, hinge housings, deep horizontal bores, edge trimming, etc.).

**Horizontal motor with one or two outlets** for lock routing and horizontal machining operations.



**Fixed vertical motor** dedicated to additional milling machining operations (slot, anti-splintering, etc.).

# Loading and unloading solutions

**Biesse can provide a variety of integrated solutions depending on specific productivity, automation and footprint requirements.**



With the introduction of the **RBO RT** range, Biesse further complemented its range of customised products where flexibility and logistics are key elements in order to provide automated process solutions.



# Technical specifications

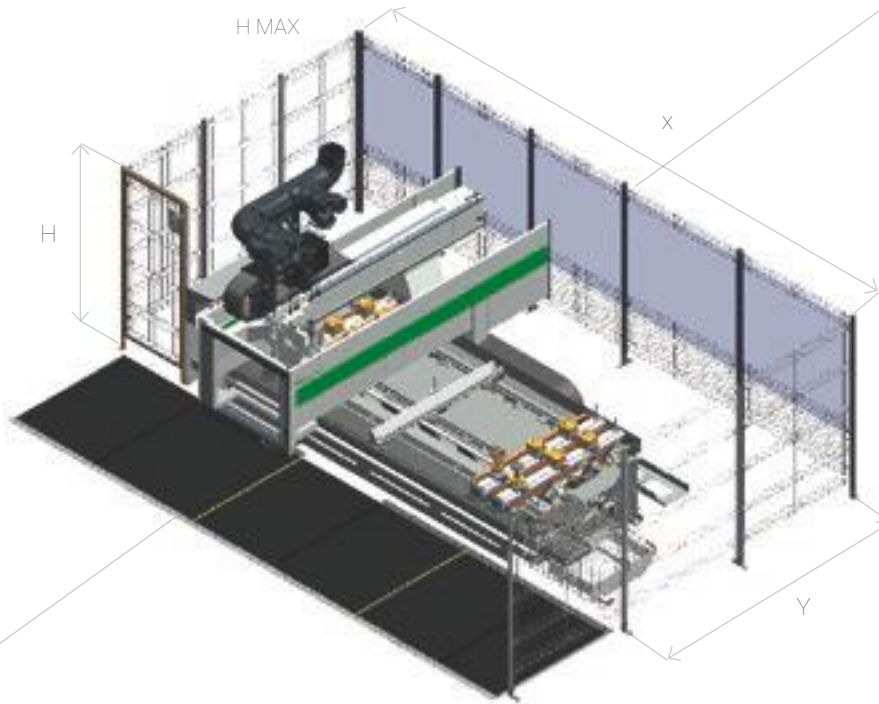

	XCE	XNCE	Y	Z
	(mm / inch)	(mm / inch)	(mm / inch)	(mm / inch)
Rover A 1425	2500/98	2500/98	1320/52	225/9
Rover A 1432	3280/129	3280/129	1320/52	225/9
Rover A 1443	4320/170	4320/170	1320/52	225/9
Rover A 1459	5920/233	5920/233	1320/52	225/9
Rover A 1625	2500/98	2500/98	1580/62	225/9
Rover A 1632	3280/129	3280/129	1580/62	225/9
Rover A 1643	4320/170	4320/170	1580/62	225/9
Rover A 1659	5920/233	5920/233	1580/62	225/9



	loadable panel	X CE photocells + bumper	Y CE photocells + bumper	X NCE photocells + bumper	Y NCE photocells + bumper	H	H MAX
	(mm / inch)	(mm / inch)	(mm / inch)	(mm / inch)	(mm / inch)	(mm / inch)	(mm / inch)
Rover A 1425	2100/83	5712/225	5659/223	5423/214	4765/188	2400/95	2700/107
Rover A 1432	2100/83	7050/278	5008/198	6497/256	4820/190	2400/95	2700/107
Rover A 1443	2100/83	8080/319	5008/198	7560/298	4820/190	2400/95	2700/107
Rover A 1459	2100/83	9684/382	5008/198	9130/360	4820/190	2400/95	2700/107
Rover A 1625	2100/83	5712/225	5659/223	5423/214	4765/188	2400/95	2700/107
Rover A 1625	2100/83	5712/225	5659/223	5423/214	4765/188	2400/95	2700/107
Rover A 1632	2100/83	7050/278	5008/198	6497/256	4820/190	2400/95	2700/107
Rover A 1643	2100/83	8080/319	5008/198	7560/298	4820/190	2400/95	2700/107
Rover A 1659	2100/83	9684/382	5008/198	9130/360	4820/190	2400/95	2700/107

	loadable panel	X CE photocells + bumper	Y CE photocells + bumper	X NCE photocells + bumper	Y NCE photocells + bumper	H	H MAX
	(mm / inch)	(mm / inch)	(mm / inch)	(mm / inch)	(mm / inch)	(mm / inch)	(mm / inch)
Rover A 1432	2100/83	6445/254	4834/191	6493/256	5686/224	2400/95	2700/107
Rover A 1443	2100/83	7465/294	4834/191	7560/298	5686/224	2400/95	2700/107
Rover A 1459	2100/83	9111/359	4834/191	9130/360	5686/224	2400/95	2700/107
Rover A 1632	1900/75	6445/254	4634/183	6493/256	5686/224	2400/95	2700/107
Rover A 1632	2100/83	6445/254	4834/191	6493/256	5686/224	2400/95	2700/107
Rover A 1643	1900/75	7465/294	4634/183	7560/298	5686/224	2400/95	2700/107
Rover A 1643	2100/83	7465/294	4834/191	7560/298	5686/224	2400/95	2700/107
Rover A 1659	1900/75	9111/359	4634/183	9130/360	5686/224	2400/95	2700/107
Rover A 1659	2100/83	9111/359	4834/191	9130/360	5686/224	2400/95	2700/107
X/Y/Z axis speed	60/60/20 m/min				85/60/20 m/min		
Vector speed	85 m/min				104 m/min		
The technical specifications and drawings are non-binding. Some photos may show machines equipped with optional features. Biesse Spa reserves the right to carry out modifications without prior notice.							

The measurement was carried out in compliance with UNI EN 848-3:2007, UNI EN ISO 3746: 2009 (sound power) and UNI EN ISO 11202: 2009 (sound pressure levels at workstation) during panel machining. The noise levels shown are emission levels and do not necessarily correspond to safe operation levels. Despite the fact that there is a relationship between emission and exposure levels, this may not be used in a reliable manner to establish whether further measures need to be taken. The factors determining the exposure level for the workforce include length of exposure, work environment characteristics, other sources of dust and noise, etc. i.e. the number of other adjoining machines and processes. At any rate, the above information will enable the operator to better evaluate dangers and risks.

A weighted sound pressure level (LpA) during machining for operator workstation on vane-pump machine Lpa=79dB(A) Lwa=96dB(A) A-weighted sound-pressure level (LpA) for operator workstation and sound power level (LwA) during machining on cam-pump machine Lwa=83dB(A) Lwa=100dB(A) K measurement uncertainty dB(A) 4

# Service & Parts

Direct, seamless co-ordination of service requests between Service and Parts. Support for Key Customers by dedicated Biesse personnel, either in-house and/or at the customer's site.

## Biesse Service

- ✓ Machine and system installation and commissioning.
- ✓ Training centre dedicated to Biesse Field engineers, subsidiary and dealer personnel; client training directly at client's site.
- ✓ Overhaul, upgrade, repair and maintenance.
- ✓ Remote troubleshooting and diagnostics.
- ✓ Software upgrade.

500 / Biesse Field engineers in Italy and worldwide

50 / Biesse engineers manning a Teleservice Centre

550 / Certified Dealer engineers

120 / Training courses in a variety of languages every year

The Biesse Group promotes, nurtures and develops close and constructive relationships with customers in order to better understand their needs and improve its products and after-sales service through two dedicated areas: Biesse Service and Biesse Parts.

With its global network and highly specialised team, it offers technical service and machine/component spares anywhere in the world on-site and 24/7 on-line.



## Biesse Parts

- ✓ Original Biesse spares and spare kits customised for different machine models.
- ✓ Spare part identification support.
- ✓ Offices of DHL, UPS and GLS logistics partners located within the Biesse spare part warehouse, with multiple daily pick-ups.
- ✓ Order fulfilment time optimised thanks to a global distribution network with de-localised, automated warehouses.

87% / of downtime machine orders fulfilled within 24 hours

95% / of orders delivered in full on time

100 / spare part staff in Italy and worldwide

500 / orders processed every day



# Made **With** Biesse

## **Biesse Group technologies join forces with Lago's innovation and total quality management processes.**

In the crowded world of domestic design, Lago takes its place as an emerging brand, thanks to a collection of stimulating products and a corporate philosophy that embraces the interaction between business and art, coupled with on-going research into sustainable development. "We created a number of projects, or rather, concepts - states Daniele Lago - that have shaped Lago as we see it today: we saw design as a cultural vision that applies not only to individual products, but rather to the entire business chain". "Flexibility is the key word here at Lago" says Carlo Bertacco, Manufacturing

Manager. "We started to introduce the concept of processing only outstanding orders, which enabled us to reduce our footprint and empty the site from the very beginning". "The machinery that we purchased - states Bertacco - is great, it entailed a limited investment versus the capabilities it offers and is linked to a specific manufacturing approach. What I am talking about is a given manufacturing volume with Lago-standard quality levels and the possibility of customising as late as possible, at the customer's request: in short, the very basic principles of lean manufacturing".

*Source: IDM Industria del Mobile  
Lago, our customer since 1999, is one of most prestigious Italian furniture brands in the world.*



<http://www.lago.it>



# Biesse Group

In

1 industrial group, 4 divisions  
and 8 production sites.

How

€ 14 million p/a in R&D and 200 patents registered.

Where

30 branches and 300 agents/selected resellers.

With

80% of its customers abroad.

We

2,700 employees throughout the world.

**Biesse Group** is a multinational leader in the technology for processing wood, glass, stone, plastic and metal.

Founded in Pesaro in 1969, by Giancarlo Selci, the company has been listed on the Stock Exchange (STAR segment) since June 2001.

 **BIESSEGROUP**

 **BIESSE**

 **INTERMAC**

 **DIAMUT**

**MECHATRONICS**

