

BIESSELCO SK 4

Numerical control beam saw



When competitiveness means growth



Made **In** Biesse

The market demands

a change in manufacturing processes, enabling companies to **accept the largest possible number of orders**. This is coupled with the need to maintain high quality standards whilst offering product customisation **with quick and defined delivery times**.

Biesse meets these requirements

with **technological solutions** which enhance and support technical expertise as well as process and material knowledge. SELCO SK 4 is the range of cutting centres designed to satisfy the needs of small to medium-sized enterprises. It is easy to use, has advanced technical solutions and features great standard equipment. The SELCO SK 4 has become the reference point in its sector.

- 
- A large industrial cutting center, the SELCO SK 4, is shown in a clean, bright environment. The machine is white with a green panel on the front that displays "SELCO SK 4". It has a large, flat worktable with a grid pattern. The background is a light, neutral color.
- ✓ **Best performance in its category.**
 - ✓ **Easy and quick to adjust for reduced cycle times.**
 - ✓ **Lean, efficient production flows.**
 - ✓ **Production increase of up to 25%.**
 - ✓ **Easy to use, with optimised machining operations.**

Intuitive cutting-edge
technology with
reduced footprint



SELCO SK 4
Numerical control beam saw



Cutting quality

Robust, balanced structure ensuring maximum stability. Specially-designed technologies to guarantee precision and rigidity.



The base of the machine is constructed from solid steel, supported by robust legs which guarantee perfect stability. The carriage rails ensure the machine remains perfectly parallel and straight, maintaining optimal tool-holder carriage balance.

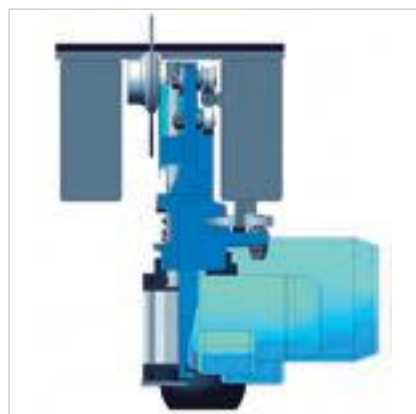

The blade is not subject to any vibration, thanks to the **upper guide**, positioned next to the blade-holder spindle.

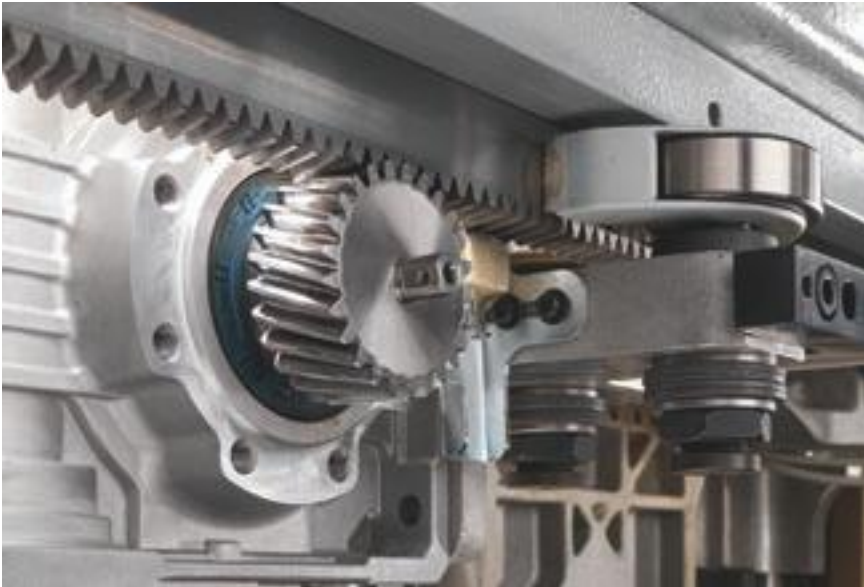

The perfectly linear movement of the tool holder carriage is achieved through a helical rack and pinion system and is driven by a brush-less servomotor.



The superior cutting quality is achieved through independent rise and fall movements of the main blade and the scoring blade.

The **projection of the main blade** is automatically adjusted by the numerical control according to the thickness of the book to be cut, obtaining the best quality cut under any working conditions. On the Selco SK 450 K1, the automatic blade projection is regulated on two levels.



Best performance in its category

Unique technical solutions on the market,
to satisfy even the most rigorous
production demands,
in terms of both precision and flexibility.



The **presser** boasts a single-element structure which guarantees consistent, controlled pressure on the book of panels to be cut. The opening is automatically optimised according to the thickness of the book of panels, in order to achieve the best cut quality and to reduce cycle times.



Fast, accurate positioning of the panels for optimum cutting precision, thanks to the robust pusher carriage activated by a brushless motor. The slide surface below the pushing device is fitted with independent rollers to avoid making any marks on panels with a delicate surface.



The self-levelling, independent grippers ensure that the panels are firmly locked in place, and allow for the full expulsion of sectioned stacks from the cutting line.



Perfect alignment of very thin and/or flexible panels, minimising cycle times thanks to the **side alignment stop** integrated in the blade carriage.



Fast and easy adjustment for reduced cycle times



The **Quick change** system, patented by Biesse, is the quickest, safest and most ergonomic device for replacing blades without using specific tools.



Fast, accurate setting of the scoring and main blades, using **Digiset system**. The system also stores the information for each set of blades, ensuring repeatable and accurate alignment every time.

Reduced panel loading and unloading times

On request special solutions are available for the movement of packs and to permit the loading and unloading of panels.



The compact, integrated **lifting table** allows for packs of panels of up to 630 mm to be loaded directly onto the steel profiles. The lifting table can also be installed as an option.



The **grippers** automatically pick up the required amount of panels according to the working programme underway, increasing the efficiency and safety of the beam saw without affecting the compact overall dimensions.



The **hydraulic table** for the unloading of cut material onto pallets is equipped with a reference stop which can be manually adjusted and over-ridden to facilitate pallet removal.

Lean, efficient production flows

Winstore K3 is an automated magazine for the optimised management of panels for companies who wish to increase their productivity, guaranteeing production with reduced times and costs.

- ✓ **Rapid return on investment thanks to increased efficiencies and cost reduction.**
- ✓ **Production flow optimisation.**
- ✓ **Integration in the production line.**





The Winstore K3 ensures that the panels to be worked are easily accessible at all times, so it is possible to substantially increase cell productivity compared to manual loading methods using a forklift truck, without frequent stack changes.

- ✓ **Reduced delivery times.**
- ✓ **Reduced warehouse space required.**
- ✓ **Reduced labour.**
- ✓ **Reduced waste.**
- ✓ **Reduced raw material usage.**

Two beam saws in one

The Twin Pusher, an exclusive patent for all Biesse beam saws, consists of two complementary pushing devices. An additional stop allows independent cutting of strips of up to 650 mm wide.

TWINPUSHER

Increased productivity by up to 25%, optimum management of production efficiencies and a ROI within the first year. A perfect combination of Biesse optimisation and Italian genius.



Productivity increase of up to 25%

Two cutting stations on a single
beam saw.



The **Twin Pusher** system is equipped with an auxiliary pushing device consisting of a gripper with side positioning by means of the numerical control. Allows for simultaneous cutting, dramatically reducing cycle times.





Differentiated cross cut.



Differentiated cross cut for narrow strips.



Rip and cross-cuts are performed at the same time. An additional stop allows independent cutting of strips of up to 650 mm wide.

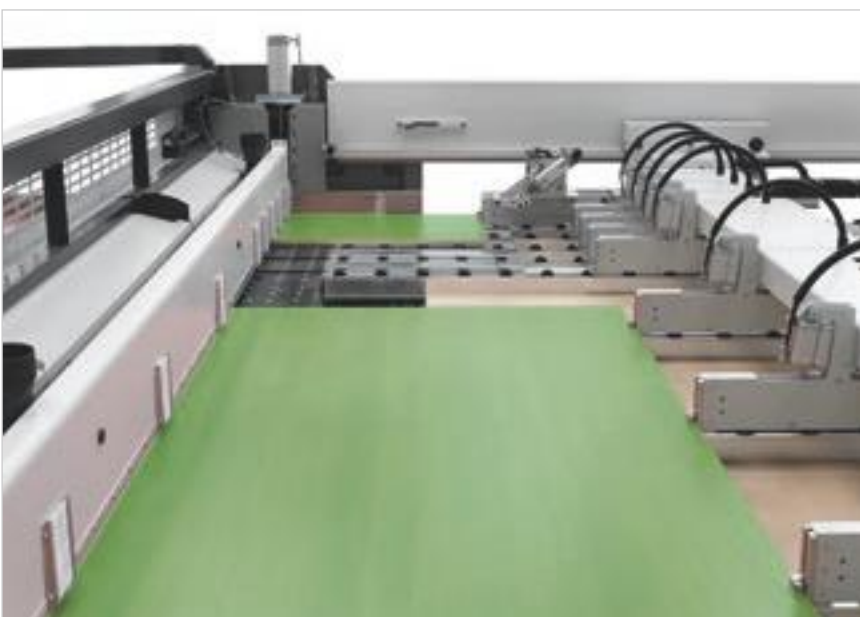

Technological solutions for every machining need

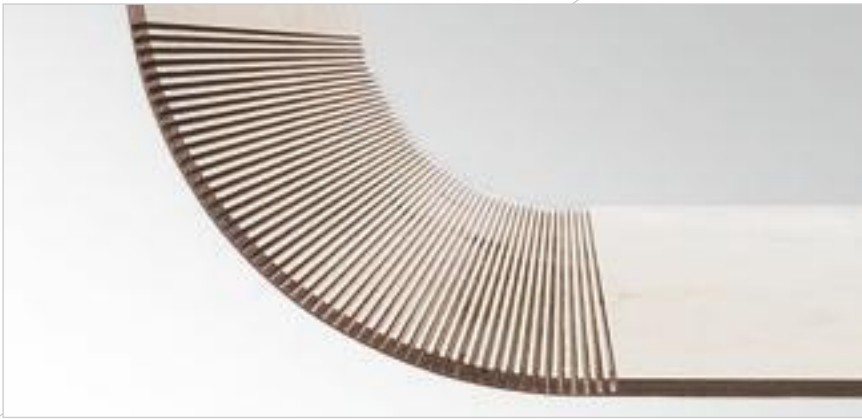

System for the automatic execution of grooves, the width of which can be programmed via the numerical control. The groove depth can be adjusted manually from the outside of the machine and with the blades moving.



Excellent product quality, thanks to the **air cushioned working surface**, which protects delicate materials. In addition, this characteristic ensures the surface next to the blade is kept constantly clean.

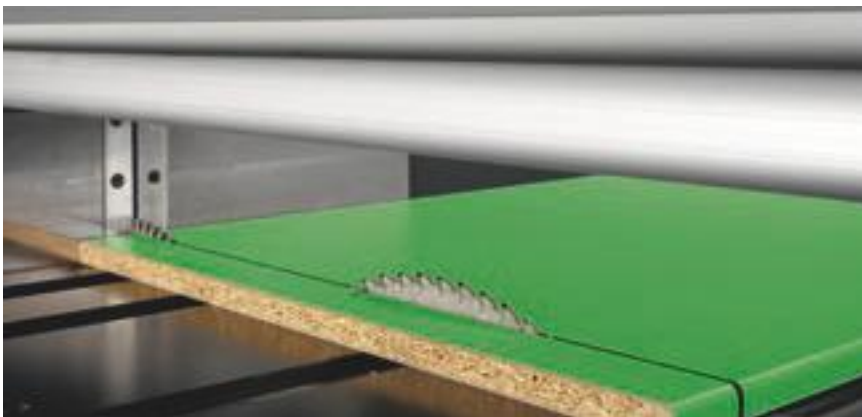

PFS function for making cuts on soft and post-formed panels. A special NC program that ensures the perfect finish of both the entrance point and the exit profile, preventing any splintering of fragile, delicate materials (patented).



Automatic device for making angled cuts.



Grippers with specific stops for processing books of laminated materials with protruding edges.



Software for making window cuts on panels. The layouts can be stored on the numerical control.

Easy to use, with optimised machining operations

The **OSI (Open Selco Interface) numerical control** guarantees the management of the execution of cutting patterns, and optimizes all movements relative to controlled axis (i.e. Pusher and Saw Carriage, pressure beam, blade height). It ensures the blade protrudes from the book to the correct degree during sectioning, and calculates the most suitable cutting speed on the basis of the book height and trim cut width. It helps ensure the best cutting quality at all times.

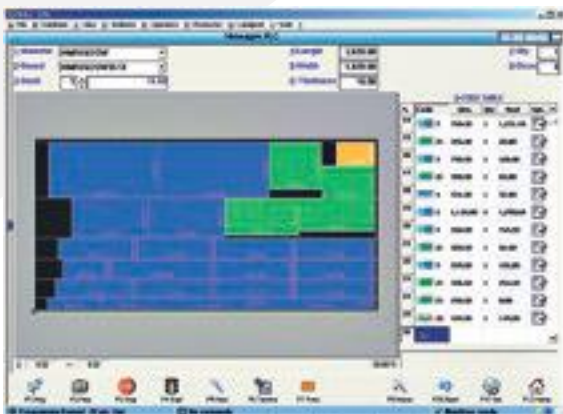

Easy cutting pattern programming.



Graphic simulation in real time, with messages and information for the operator.



Interactive program for the quick, easy execution of cuts and grooves, even on recycled panels.



An effective diagnosis and troubleshooting program provides complete information (photos and text) to ensure that any problems are quickly resolved.

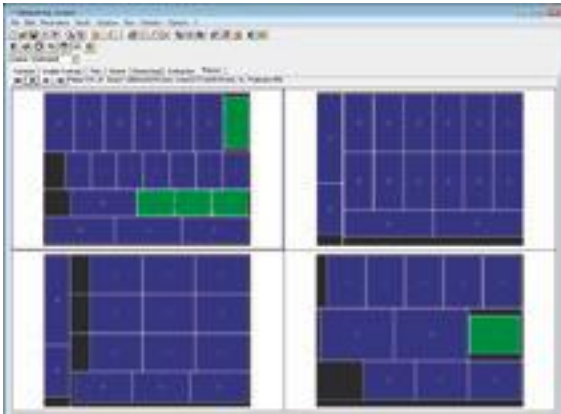

OptiPlanning

Software to optimise cutting patterns and maximise efficiency for both material costs and cutting times.

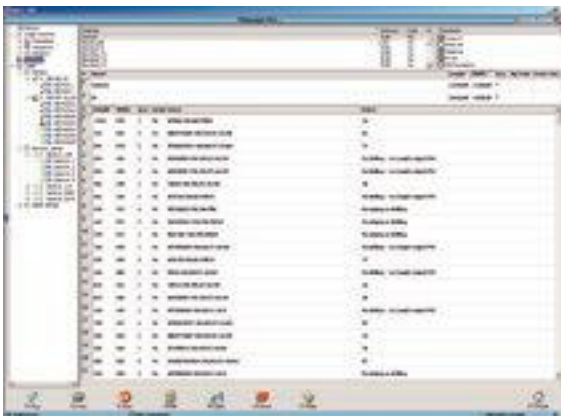

Quick Opti

Simple, intuitive software for optimising the cutting patterns directly on the machine.*



Labelling

A special software creates individual labels and prints them in real time, on the machine.



Barcode scanner

Device for automatically accessing machine operation patterns, for automated management of the remaining reusable cut material.

Technical specifications

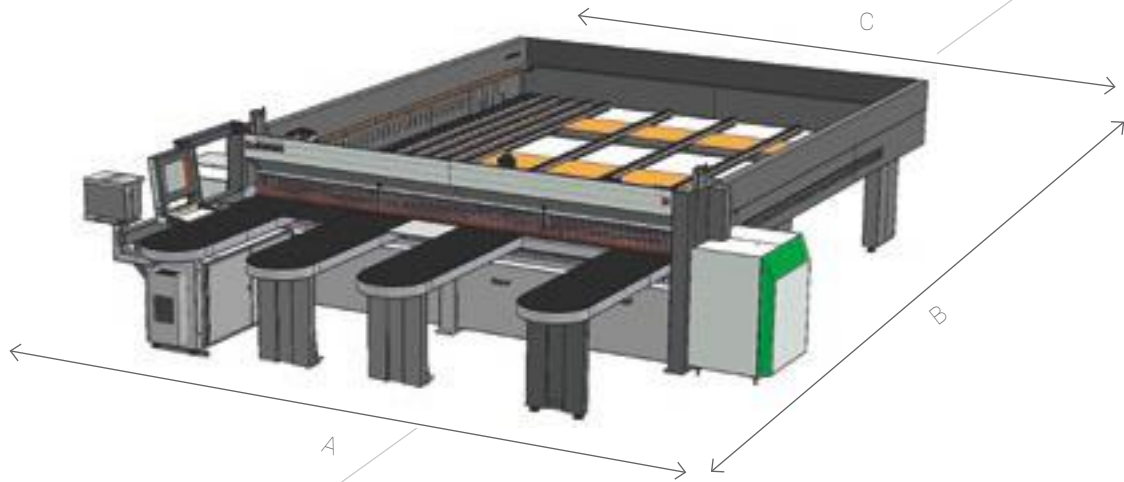

SELCO SK 4

	3200X3200	3800X3200	3800X3800	4500X4500
	mm	mm	mm	mm
A	5240	5840	5840	6340
B	6520	6520	7200	7670
C	3640	4240	4240	4740

		450 K1 / 450 K2	470 K1 / 470 K2
Maximum blade protrusion	mm	75	90
Main blade motor	kW/Hz	7.5 - 50 / 9 - 60	11 - 50 / 13.2 - 60
Engraver blade motor	kW/Hz	2.2 - 50 / 2.6 - 60	
Blade carriage transfer		brushless	
Blade carriage speed	m/min	1-120	
Pushing device transfer		brushless	
Pushing device speed	m/min	60	

The technical specifications and drawings are non-binding. Some photos may show machines equipped with optional features. Biesse Spa reserves the right to carry out modifications without prior notice.

A-weighted surface sound pressure level (L_{pfA}) during machining for operator workstation on vane-pump machine L_{pa}=83dB(A) L_{wa}=106dB(A) A-weighted sound-pressure level (L_{pA}) for operator workstation and sound power level (L_{WA}) during machining on cam-pump machine L_{wa}=83dB(A) L_{wa}=106dB(A) K measurement uncertainty dB(A) 4

The measurement was carried out in compliance with UNI EN 848-3:2007, UNI EN ISO 3746: 2009 (sound power) and UNI EN ISO 11202: 2009 (sound pressure levels at workstation) during panel machining. The noise levels shown are emission levels and do not necessarily correspond to safe operation levels. Despite the fact that there is a relationship between emission and exposure levels, this may not be used in a reliable manner to establish whether further measures need to be taken. The factors determining the exposure level for the workforce include length of exposure, work environment characteristics, other sources of dust and noise, etc. i.e. the number of other adjoining machines and processes. At any rate, the above information will enable the operator to better evaluate dangers and risks.

The Biesse sizing range

SINGLE-LINE BEAM SAWS



SELCO SK 4



SELCO WN 6



SELCO WN 7

ANGLE SAWS



SELCO WNA 6



SELCO WNA 7

Service & Parts

Direct, seamless co-ordination of service requests between Service and Parts.
Support for Key Customers by dedicated Biesse personnel, either in-house and/or at the customer's site.

Biesse Service

- ✓ Machine and system installation and commissioning.
- ✓ Training centre dedicated to Biesse Field engineers, subsidiary and dealer personnel; client training directly at client's site.
- ✓ Overhaul, upgrade, repair and maintenance.
- ✓ Remote troubleshooting and diagnostics.
- ✓ Software upgrade.

500 / Biesse Field engineers in Italy and worldwide.

50 / Biesse engineers manning a Teleservice Centre.

550 / Certified Dealer engineers.

120 / Training courses in a variety of languages every year.

The Biesse Group promotes, nurtures and develops close and constructive relationships with customers in order to better understand their needs and improve its products and after-sales service through two dedicated areas: Biesse Service and Biesse Parts.

With its global network and highly specialised team, it offers technical service and machine/component spares anywhere in the world on-site and 24/7 on-line.



Biesse Parts

- ✓ Original Biesse spares and spare kits customised for different machine models.
- ✓ Spare part identification support.
- ✓ Offices of DHL, UPS and GLS logistics partners located within the Biesse spare part warehouse, with multiple daily pick-ups.
- ✓ Order fulfilment time optimised thanks to a global distribution network with de-localised, automated warehouses.

87% ✓ of downtime machine orders fulfilled within 24 hours.

95% ✓ of orders delivered in full on time.

100 ✓ spare part staff in Italy and worldwide.

500 ✓ orders processed every day.

Made **With** Biesse

Biesse technology accompanies the growth of Stechert

"On these chairs sits the world" is the motto of the Stechert Group that can effectively be taken literally. What began 60 years ago as a small manufacturing company for pram mouldings, furniture doors and door locks is today one of the largest international suppliers of contract and office chairs, as well as tubular steel furniture. Moreover, since 2011 the company has a partnership with WRK GmbH, an international specialist in podiums, conference room and grandstand seating, associated with Stechert via the joint commercial company STW. For Stechert management, however, the excellent results obtained are no excuse for resting on their laurels. On the contrary, the company is investing heavily in the Trautskirchen site to make its production even more efficient and profitable. In the search for a new machinery partner, the company's management chose the Italian manufacturer Biesse. "For the project we chose machines that already had certain options and were predisposed for automation", said Roland Palm, Biesse Area Manager. An efficient production cycle was creat-

ed in which workers are able to perform at their best after only a short training period.

At the start of the production line is the panel saw "WNT 710" with one cutting line. "Because", explained skilled cabinet maker Martin Rauscher, "we want to be able to work panels of up to 5.90 metres in order to reduce waste as much as possible." Normal rectangular panels for tables or wall panels are taken directly to the "Stream" edgebander with "AirForceSystem" technology. The Biesse edgebander has a group that activates the laminated edging material no longer via a laser beam but using hot air to obtain the so-called "zero gap". "The quality is just as good as the laser system, if not even better: with a connection power of 7.5 kW, the cost per square metre is much lower", underlined the Biesse Area Manager.

"We want to be ready for when we mould the frame ourselves and we must therefore calibrate the panels" said Martin Rauscher, "The same is true of course for solid wood and multiplex panels, which require grinding before being

painted in an external company. For both types of work a Biesse "S1" sander is used. In order to meet the needs of the future, in the Trautskirchen plant there are also two Biesse numerically controlled machining centres: a "Rover C 965 Edge" and a "Rover A 1332 R", which are perfectly complementary.

The Stechert Group also intends to strengthen sales of innovative solutions for interior fittings, with complete systems for walls, ceilings, floors and mezzanines. For panel sectioning, the Group has purchased a "Sektor 470". For other geometry, groove and spring machining as well as boring and surface milling, there are two Biesse machining centres, an "Arrow" for nesting applications, a "Rover B 440" and more recently a 5-axis machine, the "Rover C 940 R" machining centre in order to be able to produce, in particular, wall and ceiling panels machined in 3 dimensions.

Source: HK 2/2014



<http://www.stechert.de>



Biesse Group

How
Where
With
We

1 industrial group, 4 divisions and 8 production sites.

€ 14 million p/a in R&D and 200 patents registered.

33 branches and 300 agents/selected dealers.

customers in 120 countries, manufacturers of furniture, design items and door/window frames, producers of elements for the building, nautical and aerospace industries.

3,000 employees throughout the world.

Biesse Group is a multinational leader in the technology for processing wood, glass, stone, plastic and metal.

Founded in Pesaro in 1969, by Giancarlo Selci, the company has been listed on the Stock Exchange (STAR segment) since June 2001.

 **BIESSEGROUP**

 **BIESSE**

 **INTERMAC**

 **DIAMUT**

MECHATRONICS

